



Data Security Lab General Information

Overview

The aim of the lab is to get experience on using security tools. Security tools are designed to troubleshoot protocol vulnerabilities, misconfiguration, application security and weak security decisions. Using the tools, students can understand some challenges of network security. The lab should be done in groups of two persons.

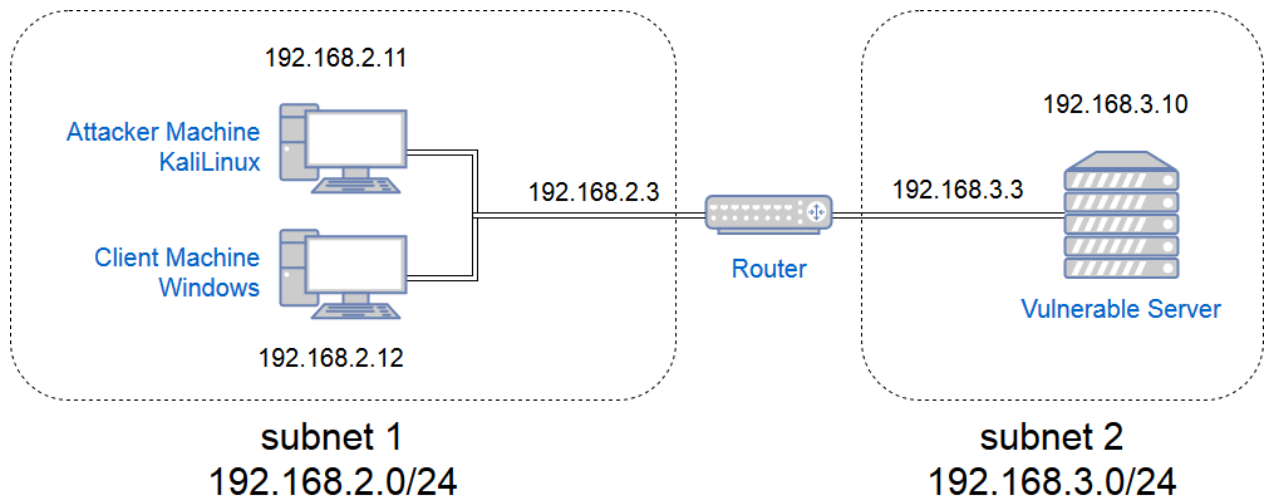

Figure 1 Lab Setup

Tasks

The Task of the lab mainly focus on different pentesting methods and different goals.

- Network traffic sniffing
- Network and port scanning
- Man-in-the-Middle attacks

The lab consists of three main tasks. Students need to compile a report on the tasks conducted and submit it.